

Linear actuators ILA Series

Linear Actuator ILA Series without input drive, with flange and input shaft



Linear Actuator ILA Series with input drive

- with bevel gearmotor



- with parallel shaft helical gearmotor

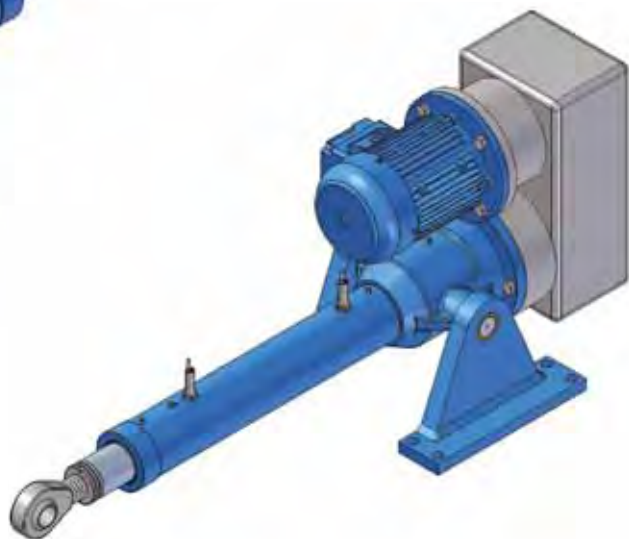

- with helical coaxial or planetary gearmotor



- with bevel-helical gearmotor



6

Linear actuators ILA Series

6.1 MANUFACTURING FEATURES

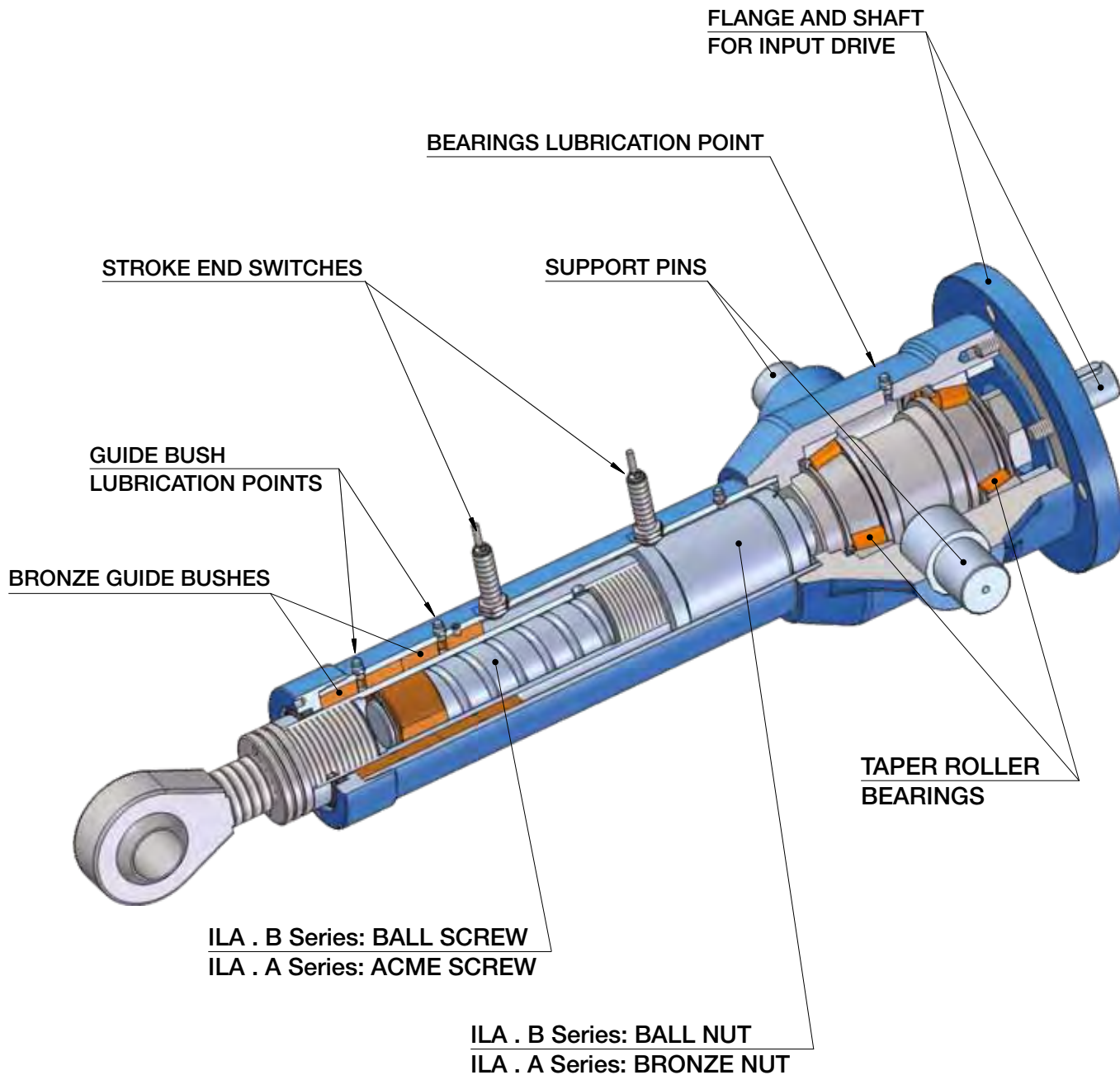

Linear actuators ILA Series

6.2 TECHNICAL DATA - acme screw linear actuators ILA . A Series

SIZE		ILA 15 A	ILA 25 A	ILA 50 A
Load capacity [kN], (push - pull)		15	25	50
Push rod diameter	[mm]	40	50	60
Outer tube diameter	[mm]	60	70	90
Front attachment diameter	[mm]	20	30	35
Rear attachment diameter - pins	[mm]	20	30	35
Max. input solid shaft diameter	[mm]	12	16	24
1-start acme screw (code: 1)		Tr 22×5	Tr 30×6	Tr 40×7
Linear travel for 1 input shaft revolution	[mm]	5	6	7
Starting efficiency		0.38	0.35	0.31
Running efficiency at 100 rpm		0.45	0.42	0.42
Reaction torque on front attachment at max. load	[Nm]	32	69	180
2-start acme screw (code: 2)		Tr 22×10 (P5)	Tr 30×12 (P6)	Tr 40×14 (P7)
Linear travel for 1 input shaft revolution	[mm]	10	12	14
Starting efficiency		0.54	0.51	0.47
Running efficiency at 100 rpm		0.61	0.59	0.58
Reaction torque on front attachment at max. load	Nm]	45	94	237
Mass (actuator 100 mm stroke length, with lubricant)	[kg]	10	17	37
Extra-mass for each additional 100 mm stroke length	[kg]	0.9	2	3

Linear actuators ILA Series

6.2 TECHNICAL DATA - acme screw linear actuators ILA . A Series

ILA 100 A	ILA 150 A	ILA 200 A	SIZE
100	150	200	Load capacity [kN], (push - pull)
80	90	110	Push rod diameter [mm]
130	150	180	Outer tube diameter [mm]
40	45	50	Front attachment diameter [mm]
40	45	50	Rear attachment diameter - pins [mm]
32	38	42	Max. input solid shaft diameter [mm]
Tr 55×9	Tr 60×12	Tr 80×12	1-start acme screw (code: 1)
9	12	12	Linear travel for 1 input shaft revolution [mm]
0.30	0.35	0.28	Starting efficiency
0.42	0.47	0.41	Running efficiency at 100 rpm
478	819	1 706	Reaction torque on front attachment at max. load [Nm]
Tr 55×18 (P9)	Tr 60×24 (P12)	Tr 80×24 (P12)	2-start acme screw (code: 2)
18	24	24	Linear travel for 1 input shaft revolution [mm]
0.46	0.51	0.43	Starting efficiency
0.58	0.63	0.58	Running efficiency at 100 rpm
562	1 124	2 222	Reaction torque on front attachment at max. load Nm
74	103	144	Mass (actuator 100 mm stroke length, with lubricant) [kg]
6	7.5	12	Extra-mass for each additional 100 mm stroke length [kg]

Linear actuators ILA Series

6.2 TECHNICAL DATA - ball screw linear actuators ILA . B Series

SIZE		ILA 15 B	ILA 25 B	ILA 50 B
Load capacity [kN], (push - pull)		15	25	50
Push rod diameter	[mm]	40	50	60
Outer tube diameter	[mm]	60	70	90
Front attachment diameter	[mm]	20	30	35
Rear attachment diameter - pins	[mm]	20	30	35
Max. input solid shaft diameter	[mm]	16	16	24
Ball screw (code: 1)	Diameter × Lead	25×6	32×10	40×10
	Ball [mm]	3.969 (5/32 ")	6.35 (1/4 ")	6.35 (1/4 ")
	Number of circuits	3	4	5
	Dynamic load C _a [N]	17 400	41 800	60 000
	Static load C _{0a} [N]	30 500	73 000	124 000
Linear travel for 1 input shaft revolution		6	10	10
Required torque on input shaft at max. load [Nm]		16	45	89
Ball screw (code: 2)	Diameter × Lead	25×10	32×20	40×20
	Ball [mm]	3.969 (5/32 ")	6.35 (1/4 ")	6.35 (1/4 ")
	Number of circuits	3	2	3
	Dynamic load C _a [N]	14 000	32 200	38 500
	Static load C _{0a} [N]	25 700	53 000	74 000
Linear travel for 1 input shaft revolution		10	20	20
Required torque on input shaft at max. load [Nm]		27	90	177
Mass (actuator 100 mm stroke length, without motor, with lubricant) [kg]		10	18	36
Extra-mass for each additional 100 mm stroke length [kg]		0.9	2	3

Linear actuators ILA Series

6.2 TECHNICAL DATA - ball screw linear actuators ILA . B Series

ILA 100 B	ILA 150 B	ILA 200 B	SIZE
100	150	200	Load capacity [kN], (push - pull)
80	90	110	Push rod diameter [mm]
130	150	180	Outer tube diameter [mm]
40	45	50	Front attachment diameter [mm]
40	45	50	Rear attachment diameter - pins [mm]
32	38	42	Max. input solid shaft diameter [mm]
50×10	63×10	80 ×16	Diameter × Lead
7.144 (9/32 ")	7.144 (9/32 ")	9.525 (3/8 ")	[mm] Ball
5	6	5	Number of circuits
83 000	112 000	149 000	[N] Dynamic load C _a
188 000	313 000	393 000	[N] Static load C _{0a}
10	10	16	Linear travel for 1 input shaft revolution
177	266	442	Required torque on input shaft at max. load [Nm]
50×20	63×20	80 ×20	Diameter × Lead
7.144 (9/32 ")	9.525 (3/8 ")	12.7 (1/2 ")	[mm] Ball
4	4	4	Number of circuits
65 000	101 000	213 000	[N] Dynamic load C _a
140 000	220 000	516 000	[N] Static load C _{0a}
20	20	20	Linear travel for 1 input shaft revolution
354	531	885	Required torque on input shaft at max. load [Nm]
72	107	146	Mass (actuator 100 mm stroke length, without motor, with lubricant) [kg]
6	6	12	Extra-mass for each additional 100 mm stroke length [kg]

Linear actuators ILA Series

6.3 OVERALL DIMENSIONS - acme screw linear actuators ILA . A Series

Lc - RETRACTED actuator length
 La - EXTENDED actuator length

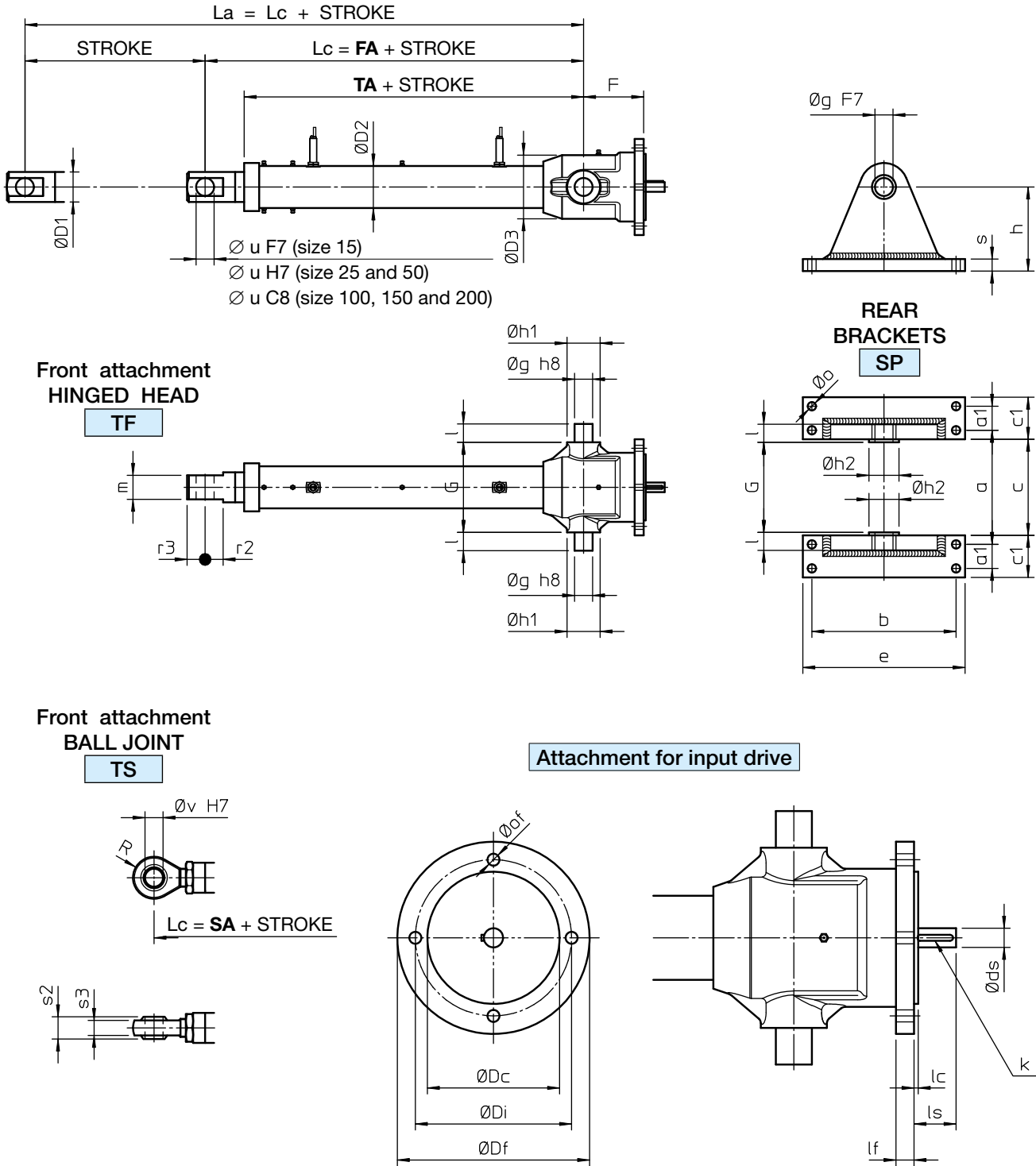

6

Linear actuators ILA Series

6.3 OVERALL DIMENSIONS - acme screw linear actuators ILA . A Series

	FA	SA	TA
ILA 15 A	207	248	166
ILA 25 A	275	310	210
ILA 50 A	351	407	282
ILA 100 A	436	466	346
ILA 150 A	468	506	376
ILA 200 A	484	519	377

Linear actuator and rear bracket dimensions:

	∅ D1	∅ D2	∅ D3	F	G	a	a1	b	c
ILA 15	40	60	86	78	140	172	26	190	148
ILA 25	50	70	106	98	150	190	40	240	160
ILA 50	60	90	140	114	200	240	50	270	210
ILA 100	80	130	170	147	240	292	60	310	252
ILA 150	90	150	190	149	280	342	75	370	292
ILA 200	115	180	220	150	332	404	100	410	344

	c1	e	∅ g	h	∅ h1	∅ h2	l	∅ o (n° of bores)	s
ILA 15	50	220	20	120	45	35	20	12 (4 bores)	15
ILA 25	70	270	30	140	55	50	30	14 (4 bores)	20
ILA 50	80	300	35	160	65	55	35	18 (4 bores)	20
ILA 100	100	360	40	185	75	60	40	22 (4 bores)	25
ILA 150	125	425	45	225	75	65	45	26 (4 bores)	30
ILA 200	160	470	50	250	100	70	50	32 (4 bores)	35

Input drive attachment dimensions:

	∅ Df	∅ Di	∅ Dc	∅ ds	k	lc	lf	ls	∅ of (n° of bores)
ILA 15 A	140	120	100	12	4x4x25	3.5	17	35	8 (4 bores)
ILA 25 A	160	140	120	16	5x5x30	3.5	13	40	10 (4 bores)
ILA 50 A	200	175	150	24	8x7x35	4	19	55	12.5 (4 bores)
ILA 100 A	250	215	180	32	10x8x40	4	25	60	14.5 (4 bores)
ILA 150 A	300	265	230	38	10x8x60	4	29	78	14.5 (4 bores)
ILA 200 A	350	300	250	42	12x8x60	4	33	110	18.5 (4 bores)

NOTE: On request, the dimensions of the input drive attachment can be different according to the dimensions of the drive unit to be mounted.

Front attachment dimensions:

	m	R	r2	r3	s2	s3	∅ u	∅ v
ILA 15 A	42	25	—	27	25	19	20	20
ILA 25 A	40	35	30	30	37	25	30	30
ILA 50 A	50	40	30	35	43	28	35	35
ILA 100 A	60	45	45	55	28	23	40	40
ILA 150 A	70	51	50	60	32	27	45	45
ILA 200 A	80	68	60	70	44	38	60	60



Linear actuators ILA Series

6.3 OVERALL DIMENSIONS - ball screw linear actuators ILA . B Series

Lc - RETRACTED actuator length
 La - EXTENDED actuator length

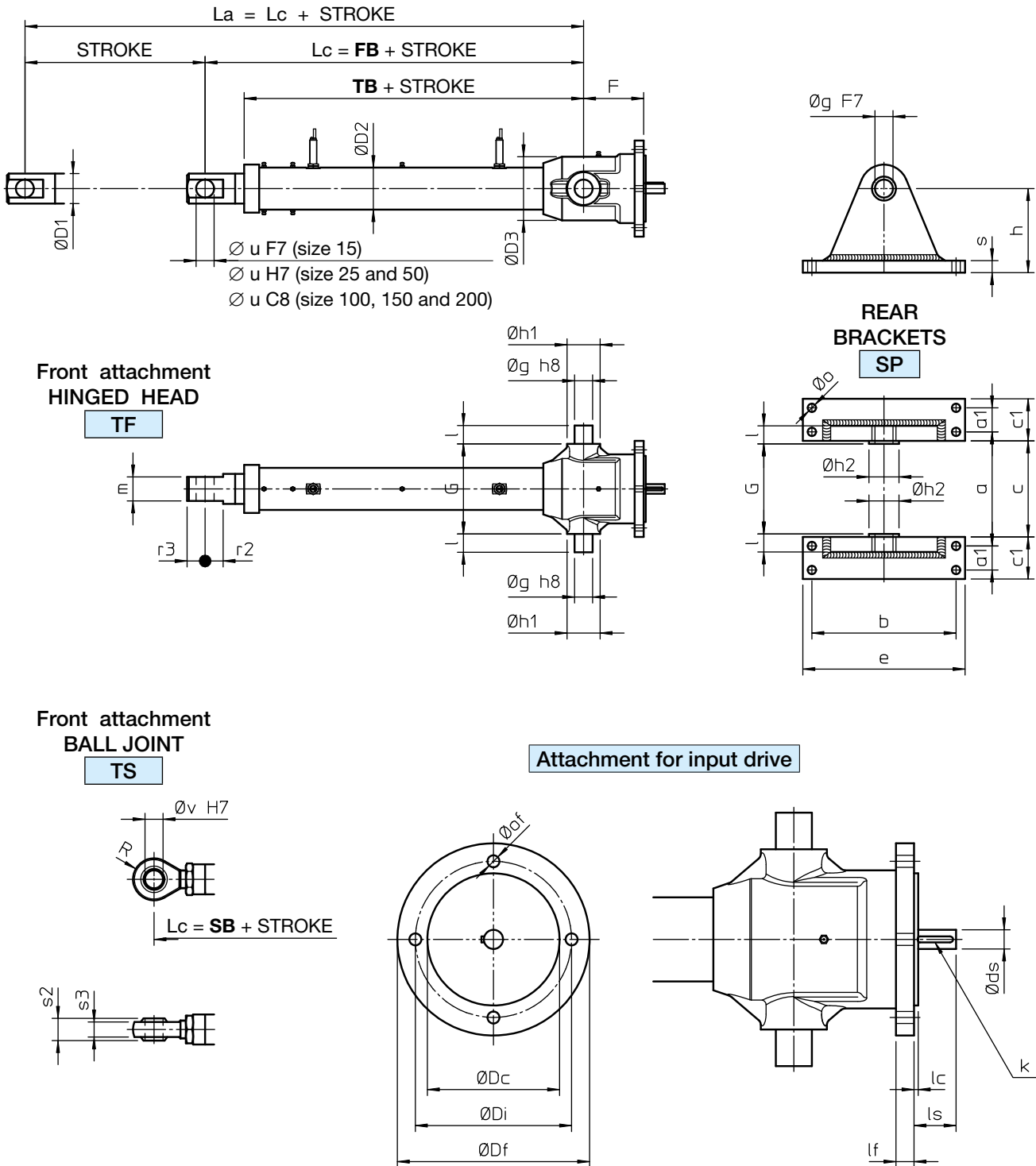

6

Linear actuators ILA Series

6.3 OVERALL DIMENSIONS - ball screw linear actuators ILA . B Series

	FB		SB		TB	
ILA 15 B	190 (BS 25×6)	208 (BS 25×10)	231 (BS 25×6)	249 (BS 25×10)	148 (BS 25×6)	166 (BS 25×10)
ILA 25 B	330		365		267	
ILA 50 B	371 (BS 40×10)	391 (BS 40×20)	427 (BS 40×10)	447 (BS 40×20)	309 (BS 40×10)	329 (BS 40×20)
ILA 100 B	436 (BS 50×10)	472 (BS 50×20)	466 (BS 50×10)	502 (BS 50×20)	344 (BS 50×10)	380 (BS 50×20)
ILA 150 B	484 (BS 63×10)	519 (BS 63×20)	522 (BS 63×10)	545 (BS 63×20)	390 (BS 63×10)	425 (BS 63×20)
ILA 200 B	532 (BS 80×16)	554 (BS 80×20)	567 (BS 80×16)	589 (BS 80×20)	432 (BS 80×16)	454 (BS 80×20)

Linear actuator and rear bracket dimensions:

	∅ D1	∅ D2	∅ D3	F	G	a	a1	b	c
ILA 15	40	60	86	78	140	172	26	190	148
ILA 25	50	70	106	98	150	190	40	240	160
ILA 50	60	90	140	114	200	240	50	270	210
ILA 100	80	130	170	147	240	292	60	310	252
ILA 150	90	150	190	149	280	342	75	370	292
ILA 200	115	180	220	150	332	404	100	410	344

	c1	e	∅ g	h	∅ h1	∅ h2	l	∅ o (n° of bores)	s
ILA 15	50	220	20	120	45	35	20	12 (4 bores)	15
ILA 25	70	270	30	140	55	50	30	14 (4 bores)	20
ILA 50	80	300	35	160	65	55	35	18 (4 bores)	20
ILA 100	100	360	40	185	75	60	40	22 (4 bores)	25
ILA 150	125	425	45	225	75	65	45	26 (4 bores)	30
ILA 200	160	470	50	250	100	70	50	32 (4 bores)	35

Input drive attachment dimensions:

	∅ Df	∅ Di	∅ Dc	∅ ds	k	lc	lf	ls	∅ of (n° of bores)
ILA 15 B	140	120	100	16	5×5×25	3.5	17	45	8 (4 bores)
ILA 25 B	160	140	120	16	5×5×30	3.5	13	40	10 (4 bores)
ILA 50 B	200	175	150	24	8×7×35	4	19	55	12.5 (4 bores)
ILA 100 B	250	215	180	32	10×8×40	4	25	60	14.5 (4 bores)
ILA 150 B	300	265	230	38	10×8×60	4	29	78	14.5 (4 bores)
ILA 200 B	350	300	250	42	12×8×60	4	33	110	18.5 (4 bores)

NOTE: On request, the dimensions of the input drive attachment can be different according to the dimensions of the drive unit to be mounted.

Front attachment dimensions:

	m	R	r2	r3	s2	s3	∅ u	∅ v
ILA 15 B	42	25	—	27	25	18	20	20
ILA 25 B	40	35	30	30	37	25	30	30
ILA 50 B	50	40	30	35	43	28	35	35
ILA 100 B	60	45	45	55	49	33	40	40
ILA 150 B	70	51	50	60	32	27	45	45
ILA 200 B	80	68	60	70	44	38	60	60

Linear actuators ILA Series

6.4 ACCESSORIES

INDUCTIVE PROXIMITY STROKE END SWITCHES Code FCP

The INDUCTIVE PROXIMITY STROKE END SWITCHES FCP allow the actuator to stop before reaching the internal mechanical stop avoiding damage. They can be also used to fix intermediate positions along the actuator stroke length.

The INDUCTIVE PROXIMITY STROKE END SWITCHES are fixed directly on the actuator outer tube in the required position. Their position is not adjustable. Standard proximity switches are normally closed.

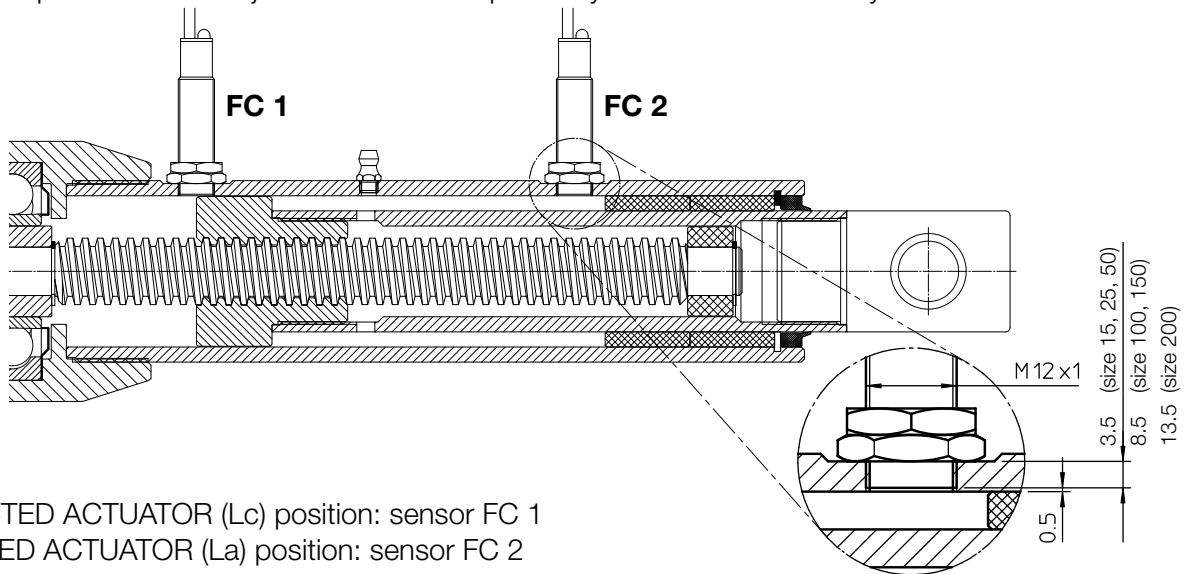

- RETRACTED ACTUATOR (Lc) position: sensor FC 1
- EXTENDED ACTUATOR (La) position: sensor FC 2

ELECTRIC FEATURES	
Type:	inductive, PNP
Contact:	normally CLOSED (NC)
Voltage:	(10 ... 30) V DC
Max. output current:	200 mA
Voltage drop (activated switch)	< 3 V (at 200 mA)
Wires:	3 × 0.2 mm ²
Cable length:	2 m

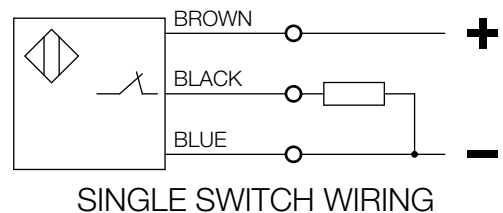

SAFETY NUT Code MS

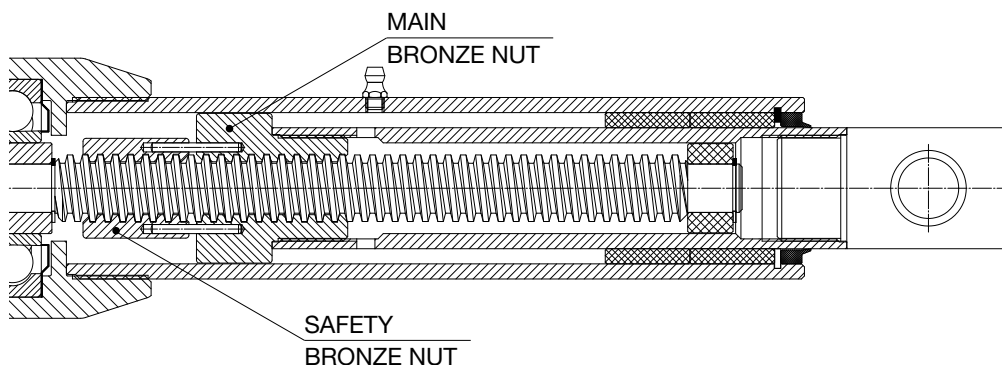

The SAFETY NUT is an auxiliary bronze nut connected by 2 pins to the main bronze nut. The distance between the two nuts in a new actuator is equal to a half of the thread pitch. If the main nut wears up to a half of the thread pitch or crashes, the SAFETY NUT supports the load avoiding its fall down.

The SAFETY NUT is a one-direction device. Its position with respect to the main nut depends on the load direction. The SAFETY NUT is available for actuators working with push load. For applications with pull load a special design is available (contact SERVOMECH).

The SAFETY NUT MS is available for all acme screw actuators (ILA . A Series).

ANTI-TURN device Code AR

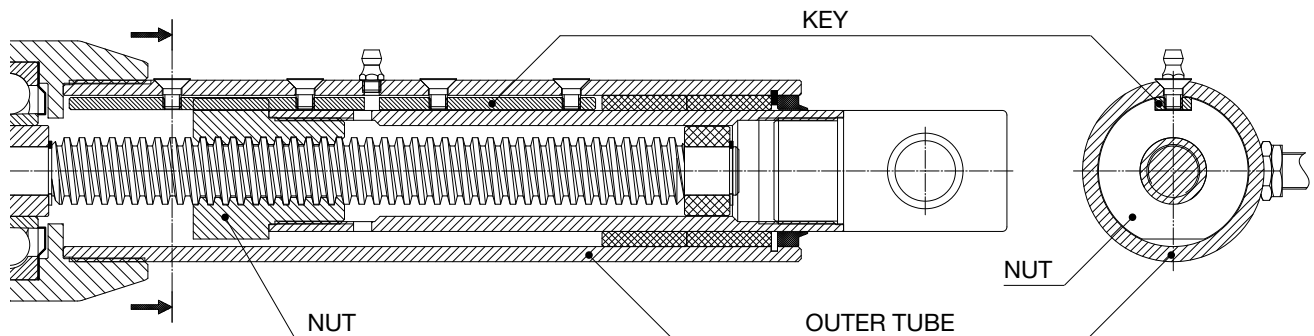

To achieve a linear motion it is necessary to prevent the rotary movement of the nut and of the push rod fixed to it. In many applications it is the external structure itself that, being connected to the push rod, prevents the rotation and allows the linear motion.

In some cases the load applied on the push rod cannot be guided and therefore the rotation cannot be avoided. In such cases it is necessary to use actuators with an internal anti-turn device. The ANTI-TURN device allows the linear motion without any external reaction on the push rod. It can be supplied upon request.

The anti-turn device shown in the above picture consists in a steel key fixed and aligned along the outer tube. The bronze nut, provided with a suitable keyway, slides on this key, making translate the push rod.

The ANTI-TURN device AR is available for all acme screw actuators (ILA . A Series).

PROTECTIVE BELLOWS Code B

When the actuators are used in severe environment conditions with contaminant agents that can damage the seal scraper between the outer outer tube and the push rod, BELLOWS protection can be useful.

Bellows made of special materials for severe environments are available upon request.



Linear actuators ILA Series

6.5 ORDERING CODE

ILA	25	A	Tr 30x6	C400	TS	SP	FC	
1	2	3	4	5	6	7	8.A	
gearbox ...								
9								
AC 3-phase motor 1.5 kW 4-pole 230/400 V 50 Hz IP 55 Ins. F								
10								

1	Actuator series ILA	
2	Actuator size 15, 25, 50, 100, 150, 200	pages 186 ... 189
3	Type of linear drive screw A - acme screw B - ball screw	pages 186 ... 189
4	Linear drive screw	pages 186 ... 189
5	Stroke code	
6	Front attachment TS - ball joint TF - hinged head	pages 190 ... 193
7	Rear attachment (without code) - pins SP - rear brackets	pages 190 ... 193
8	Stroke end switches FCP - inductive proximity switches	page 194
9	Input drive gearbox data	
10	Motor data	
11	Other specifications example: push rod in stainless steel AISI 304 example: lubricant for low temperature	
12	Filled in SELECTION DATA sheet	page 197
13	Application layout	



APPLICATION: _____

REQUIRED STROKE: _____ mm

REQUIRED LINEAR SPEED: _____ mm/s _____ mm/min _____ m/min TIME TO PERFORM 1 STROKE: _____ s

STATIC LOAD: PULL: _____ N PUSH: _____ N at STROKE _____ mm

DYNAMIC LOAD: PULL: _____ N PUSH: _____ N at STROKE _____ mm

ACTUATOR SUBJECTED TO VIBRATIONS NOT SUBJECTED TO VIBRATIONS

OPERATING: _____ cycle / hour _____ working hours / day Notes: _____

REQUIRED LIFETIME: _____ cycle _____ hours _____ calendar days Notes: _____

ENVIRONMENT: TEMPERATURE _____ °C DUST HUMIDITY _____ % AGGRESSIVE AGENT _____

Acme screw actuators **ILA . A Series** Ball screw actuators **ILA . B Series**

Size: 15 25 50 100 150 200

1-start acme screw

ball screw with STANDARD lead

2-start acme screw

ball screw with LONG lead

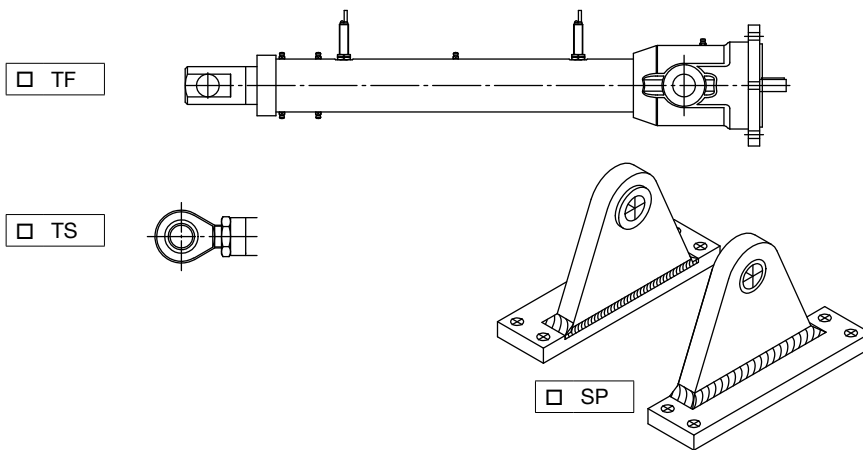

INPUT DRIVE _____

ELECTRIC MOTOR _____

ANTI-TURN DEVICE AR

SAFETY NUT MS

BELLOWS

PUSH ROD IN STAINLESS STEEL

OUTER TUBE IN STAINLESS STEEL

OTHER: _____

Acme screw actuators **ILA . A Series**

Ball screw actuators **ILA . B Series**

PRODUCT: _____

INPUT DRIVE

WITHOUT

ELECTRIC MOTOR

WITHOUT

Product serial number: _____ ; q.ty: _____

HINGED HEAD TF

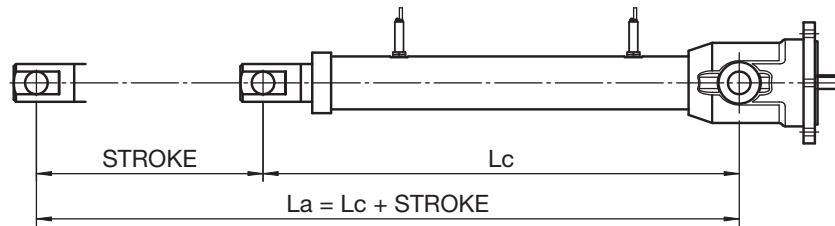

BALL JOINT TS

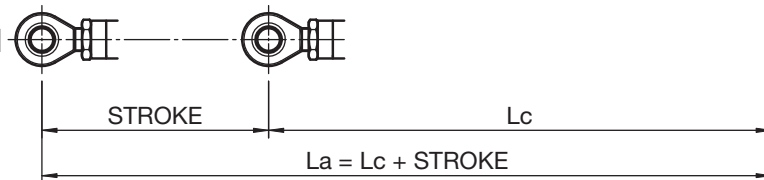

LINEAR ACTUATOR LENGTH

WORKING RANGE

RETRACTED ACTUATOR length: Lc = _____ mm
 EXTENDED ACTUATOR length: La = _____ mm
 STROKE (La - Lc): C = _____ mm

INTERNAL MECHANICAL STOP LIMIT

MIN. actuator length: _____ mm
 MAX. actuator length: _____ mm



PASSED

Date: _____

Signature: _____

PROXIMITY STROKE END SWITCHES **FCP** □

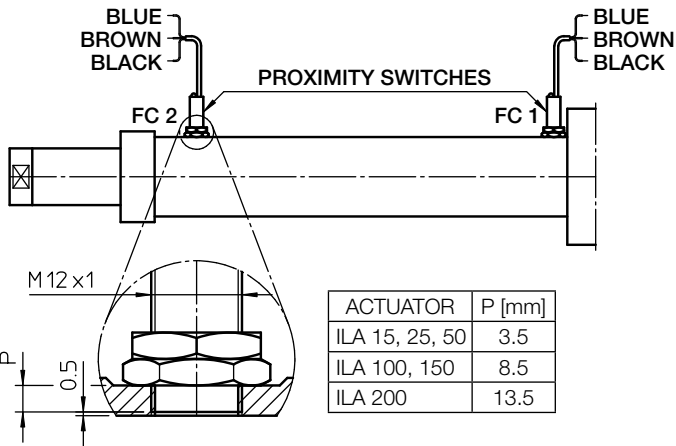

ACTUATOR	P [mm]
ILA 15, 25, 50	3.5
ILA 100, 150	8.5
ILA 200	13.5

The PROXIMITY STROKE END SWITCHES **FCP** has proximity sensors FC 1 and FC 2.

- type: inductive, PNP
- contact: **normally CLOSED**
- supply voltage: (10 ... 30) V DC
- max. output current: 200 mA
- max. voltage drop (activated sensor): < 3 V (ref. 200 mA)

FC 1 - sensor for RETRACTED ACTUATOR position
 FC 2 - sensor for EXTENDED ACTUATOR position

SINGLE SENSOR WIRING:



WARNING!

1. The values **Lc** (RETRACTED ACTUATOR length), **La** (EXTENDED ACTUATOR length) and **C** (STROKE) are the extreme limit values.
2. **BEFORE** using the linear actuator:
 - verify the input shaft rotating direction and the push rod running direction;
 - make sure that the motor and the limit switches are correctly connected and that the right voltage is used.
3. Linear actuators equipped with brake motor supplied by SERVOMECH:
 - the brake is **NORMALLY CLOSED** (NEGATIVE action). When the power supply is switched off, the brake is engaged. The brake opens only when power is supplied;
 - if the brake is wired directly to the connecting pins of the terminal box, it does not require any power supply;
 - if the brake is wired separately, make sure that the correct voltage is used;
 - if the brake is equipped with hand release device, make sure that the brake is engaged before starting the linear actuator.
4. **Alignment check:** the load must be in line with the actuator. No off-set or radial loads are allowed.

NOTE: _____

INPUT DRIVE LUBRICANT: _____
 BEARINGS LUBRICANT: _____
 SCREW – NUT LUBRICANT: _____