

## OVERALL DIMENSIONS

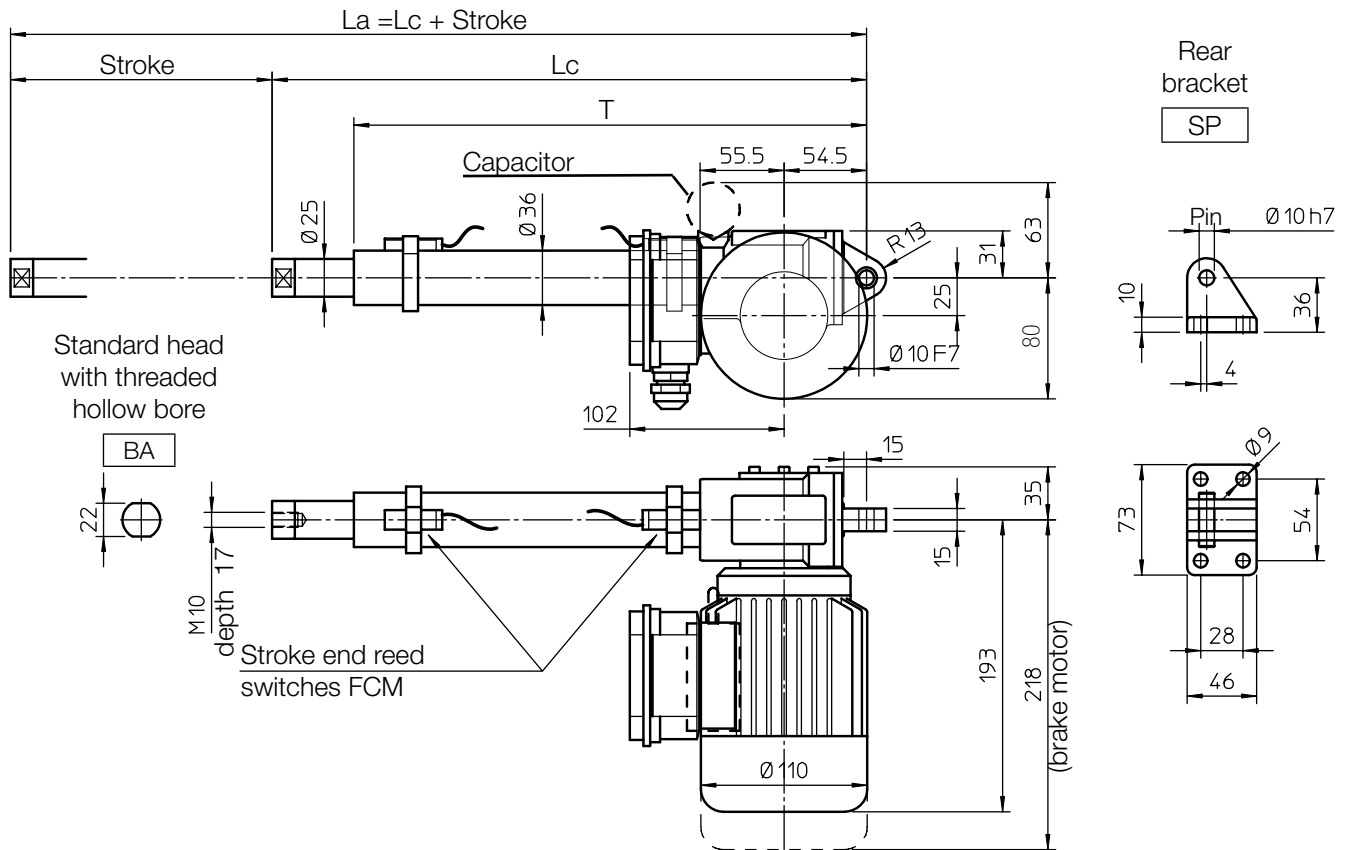

STROKE CODE	Actuator - FCE switches			Actuator - FCM switches			T [mm]	MASS [Kg]	
	STROKE [mm]	LENGTH [mm]		STROKE [mm]	LENGTH [mm]			standard motor	brake motor
		Lc [mm]	La [mm]		Lc [mm]	La [mm]			
C100	85	281	366	53	313	366	239	4.8	5.3
C150	135	331	466	103	363	466	289	4.9	5.4
C200	185	381	566	153	413	566	339	5.1	5.6
C250	235	431	666	203	463	666	389	5.2	5.7
C300	285	481	766	253	513	766	439	5.4	5.9
C400	385	581	966	353	613	966	539	5.7	6.2
C500	485	681	1166	453	713	1166	639	6.0	6.5

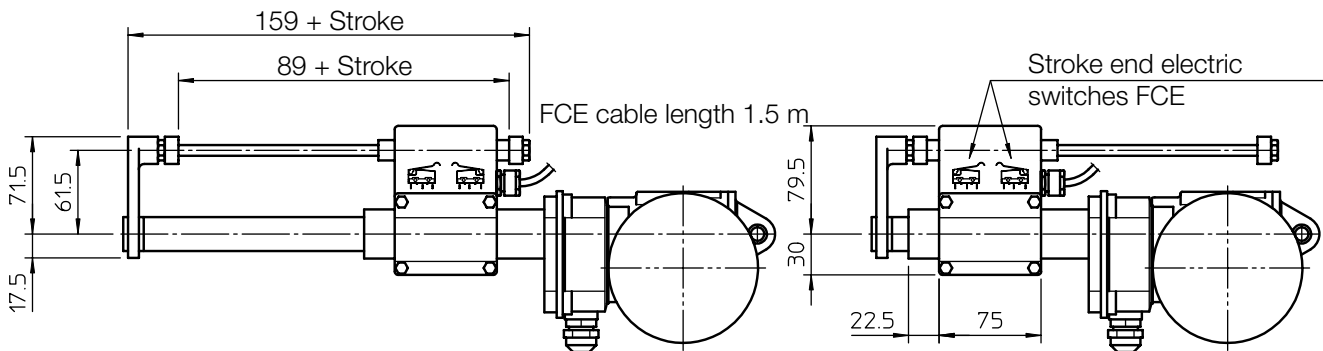

### Self-locking conditions

Self-locking condition is achievable with brake motor only.

Information about statically self-locking conditions with pull or push load on page 68.

**FRONT ATTACHMENT**

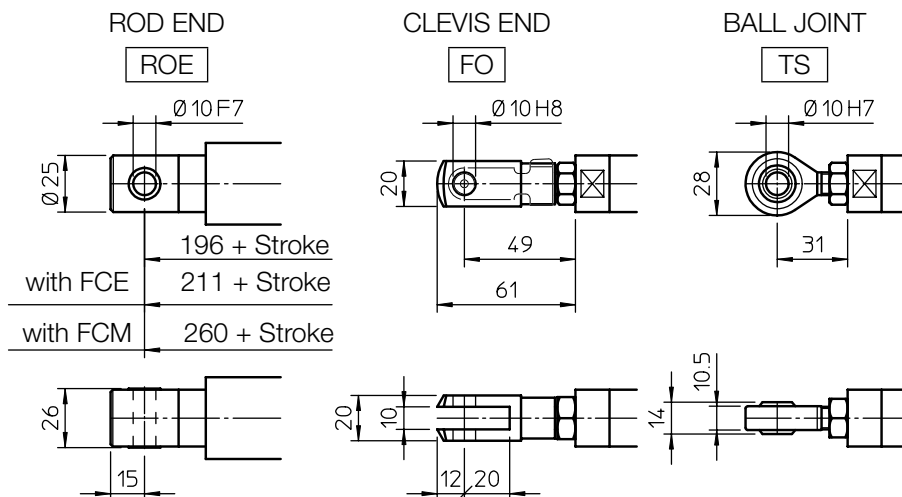

### PERFORMANCES AND FEATURES

- Push load up to 5 000 N
- Pull load up to 4 000 N
- Linear speed up to 58 mm/s
- Standard stroke lengths: 100, 150, 200, 250, 300, 400, 500 mm (for different / longer stroke lengths please contact us)
- Ball screw BS 14 x 5 (technical details on page 66)
- Aluminium alloy housing and rear attachment with bronze bush
- Anodized aluminium outer tube
- Chrome-plated steel push rod – tolerance f7
- Standard head BA or rod end ROE in stainless steel AISI 303 with bronze bush
- 3-phase or 1-phase motor (motor features details on page 70)
- Duty cycle with max load: 100% over 10 min at (-10 ... +40) °C
- Standard protection IP 55 (IP 54 with brake)
- Standard motor mounting position as per sketch (right-hand, code RH)
- Long-life lubrication, maintenance free

### ACCESSORIES

- Different front attachments
- Stainless steel push rod (code SS)
- Rear bracket (code SP)
- Mechanical overload protection: safety clutch (code FS)
- Brake motor
- Two adjustable stroke end reed switches (code FCM)
- Extra switch for intermediate position
- Electro-mechanical stroke end switch (code FCE) (for linear speed up to 30 mm/s) (technical data on page 72)

### OPTIONS

- Motor mounting position on opposite side (left-hand, code LH)
- Fixing attachment turned at 90° (code RPT 90)

### PERFORMANCES with AC 3-phase 50 Hz 230/400 V or 1-phase 50 Hz 230 V motor

Ball screw BS 14 x 5				
RATIO	0.09 kW - 4 pole motor		0.12 kW - 2 pole motor	
	LOAD [N]	SPEED [mm/s]	LOAD [N]	SPEED [mm/s]
RH1	2180	29	1490	58
RV1	3290	19	2300	37
RN1	5000	9	4230	19
RL1	5000	4.5	5000	9
RXL1	5000	2.5	5000	4.5

### ORDERING CODE EXAMPLE

BSA 10	RL1	C200	CA 230/400 V	FCM				
Actuator	Selected ratio	Required stroke	Motor	Stroke end switches	Accessories			Options

## OVERALL DIMENSIONS

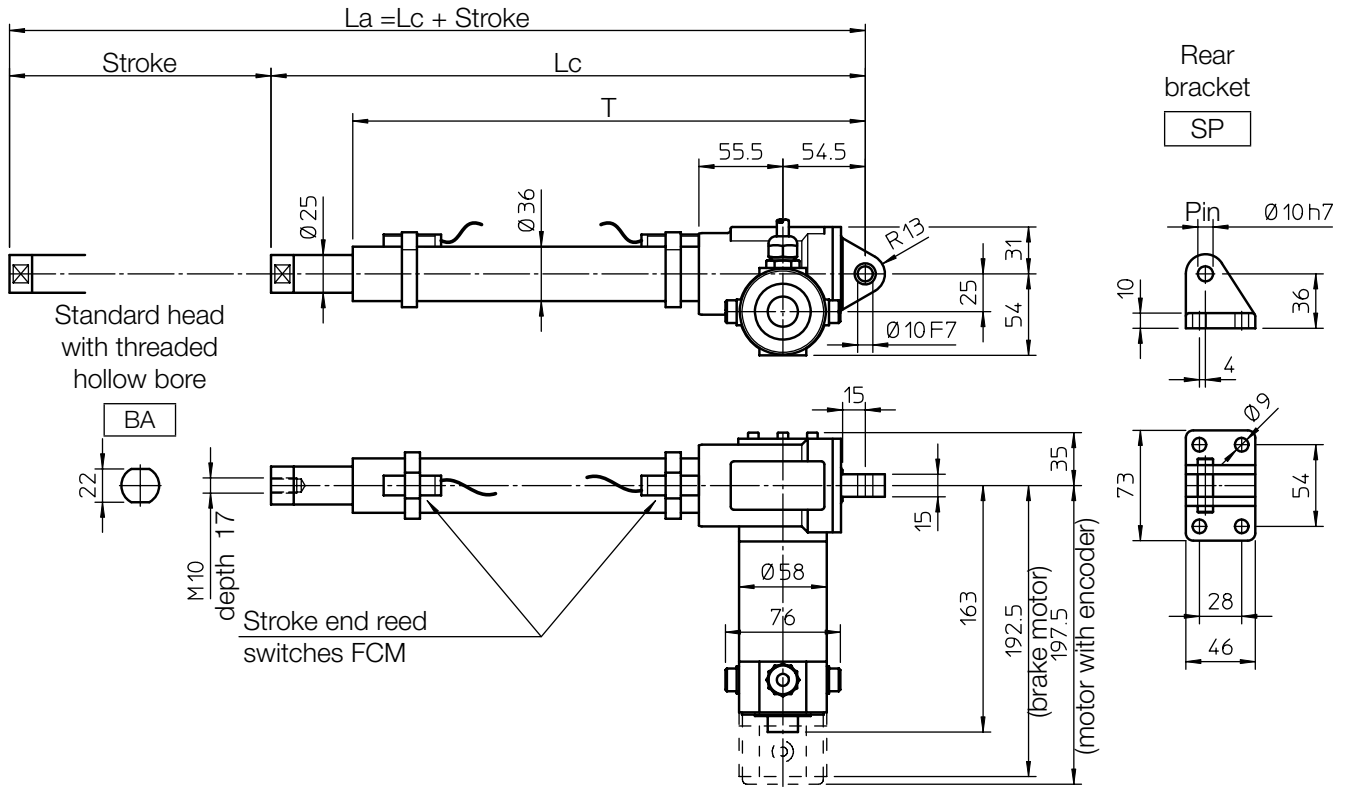

STROKE CODE	Actuator - FCE switches		Actuator - FCM switches			T [mm]	MASS [Kg]		
	STROKE [mm]	LENGTH	STROKE [mm]	LENGTH	LENGTH		standard motor	brake motor	
		Lc [mm]	La [mm]		Lc [mm]	La [mm]			
C100	85	281	366	53	313	366	239	4.8	5.3
C150	135	331	466	103	363	466	289	4.9	5.4
C200	185	381	566	153	413	566	339	5.1	5.6
C250	235	431	666	203	463	666	389	5.2	5.7
C300	285	481	766	253	513	766	439	5.4	5.9
C400	385	581	966	353	613	966	539	5.7	6.2
C500	485	681	1166	453	713	1166	639	6.0	6.5

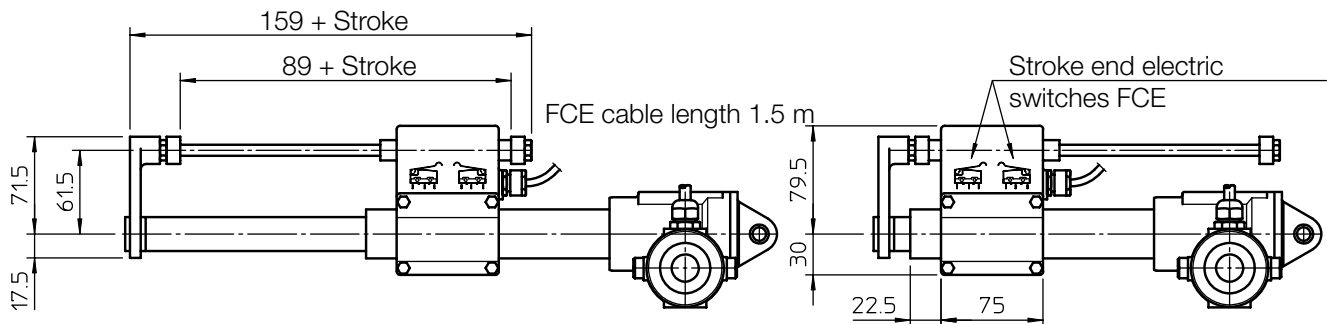

### Self-locking conditions

Self-locking condition is achievable with brake motor only.

Information about statically self-locking conditions with pull or push load on page 68.

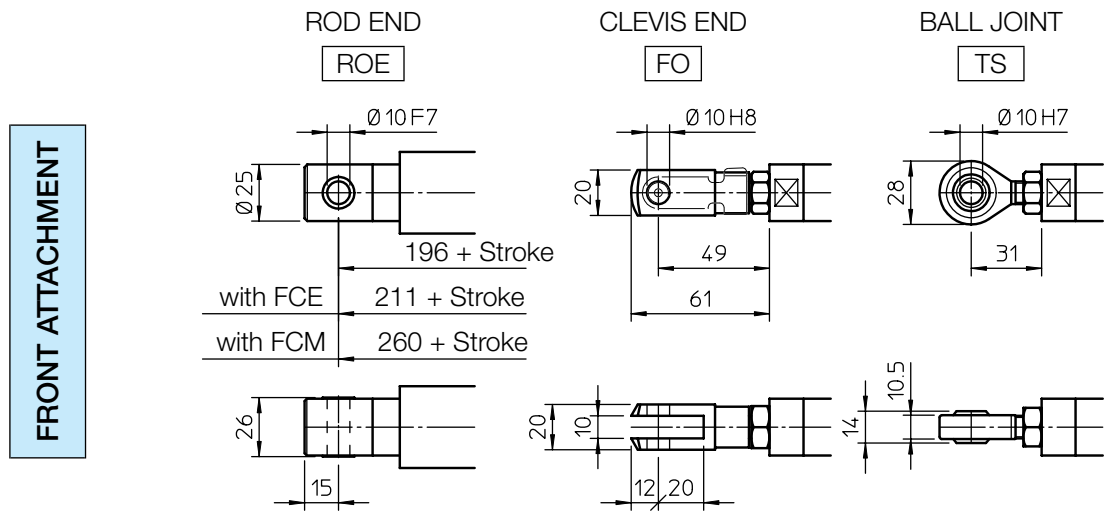

### PERFORMANCES AND FEATURES

- Push load up to 5 000 N
- Pull load up to 4 000 N
- Linear speed up to 63 mm/s
- Standard stroke lengths: 100, 150, 200, 250, 300, 400, 500 mm (for different / longer stroke lengths please contact us)
- Ball screw BS 14 x 5 (technical details on page 66)
- Aluminium alloy housing and rear attachment with bronze bush
- Anodized aluminium outer tube
- Chrome-plated steel push rod – tolerance f7
- Standard head BA or rod end ROE in stainless steel AISI 303 with bronze bush
- 12 or 24 V DC motor (motor features details on page 69)
- Duty cycle with max load: 100% over 10 min at (-10 ... +40) °C
- Standard protection IP 54
- Standard motor mounting position as per sketch (right-hand, code RH)
- Long-life lubrication, maintenance free

### ACCESSORIES

- Different front attachments
- Stainless steel push rod (code SS)
- Rear bracket (code SP)
- Mechanical overload protection: safety clutch (code FS)
- Brake motor
- Two adjustable stroke end reed switches (code FCM)
- Extra switch for intermediate position
- Electro-mechanical stroke end switch (code FCE) (for linear speed up to 30 mm/s) (technical data on page 72)
- Bi-directional incremental encoder, 100 ppr with zero set pulse, Push-Pull, 8÷24 Vcc (code EH38) (encoder features details on page 75)

### OPTIONS

- Motor mounting position on opposite side (left-hand, code LH)
- Fixing attachment turned at 90° (code RPT 90)

### PERFORMANCES with 24 V DC motor

(Performances with 12 V DC motor: same load, linear speed 10 % less, electrical consumption 2 times more)

Ball screw BS 14 x 5			
RATIO	LOAD [N]	SPEED [mm/s]	CURRENT [A]
RH1	800	63	4
RV1	1260	40	4
RN1	2350	20	4
RL1	4130	10	4
RXL1	5000	5	3

### ORDERING CODE EXAMPLE

BSA 10	RL1	C200	CC 24 V	FCM				
Actuator	Selected ratio	Required stroke	Motor	Stroke end switches	Accessories			Options

### 12.1 Ball screws

Rolled ball screw, tolerance class IT7.

Screws material: steel 42 CrMo 4 (UNI EN 10083-1) induction hardening treatment for surface hardness 58÷61 HRc

Nuts material: steel 18 NiCrMo 5 (UNI EN 10084) hardened and ground, surface hardness 58÷61 HRc, with balls surface microfinishing.

Standard axial backlash between screw and nut lower than 0.1 mm.

Executions with zero backlash or preloaded available on request.

Rolled ball screws and ball nuts are completely made in Italy, in-house manufactured by Servomech SpA S.U, Bologna.

Actuator	Ball screw	Ball diameter [mm]	Nr of ball circuits	Dynamic load $C_a$ [N]	Static load $C_{0a}$ [N]
BSA 08	BS 14 × 5	3.175	2	4 900	6 200
BSA 10	BS 14 × 5	3.175	2	4 900	6 200
BSA 11	BS 14 × 10	3.175	2	5 300	6 900
CLB 25	BS 14 × 5	3.175	2	4 900	6 200
	BS 14 × 10	3.175	2	5 300	6 900
CLB 27	BS 16 × 5	3.175	3	7 800	11 400
BSA 12	BS 20 × 5	3.175	3	9 100	15 400
UBA 0	BS 14 × 5	3.175	2	4 900	6 200
	BS 14 × 10	3.175	2	5 300	6 900

Static and dynamic load according to norm ISO 3408 and DIN 69051

## Ball screws LOAD - LIFETIME diagram

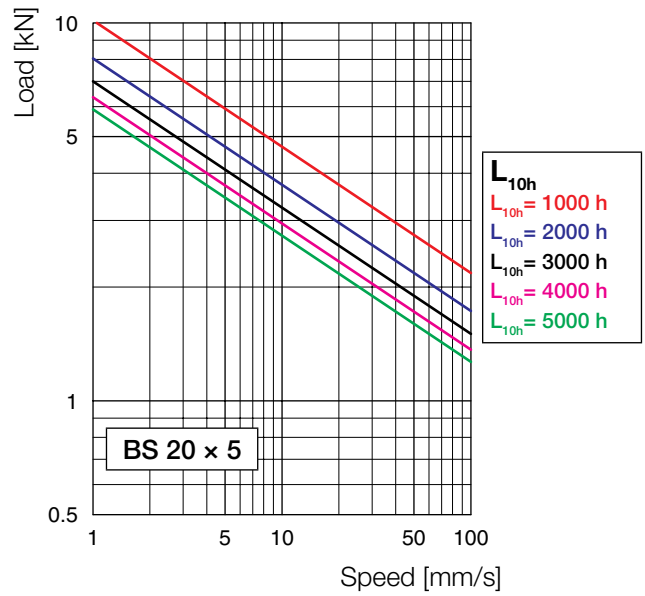
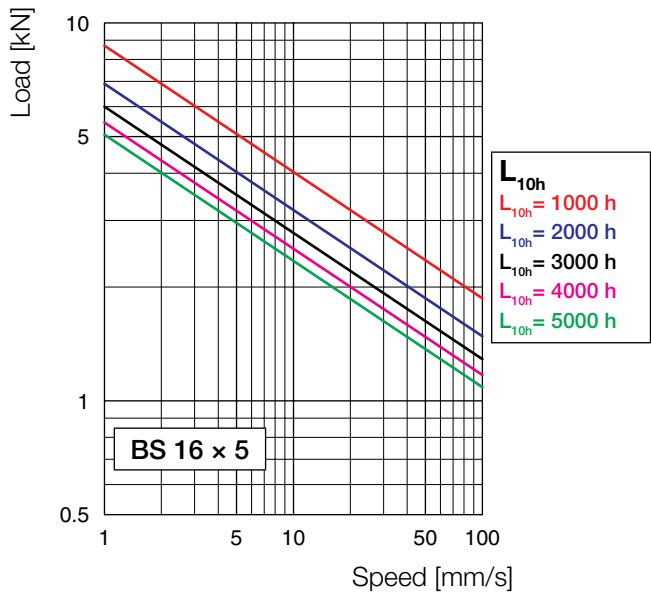
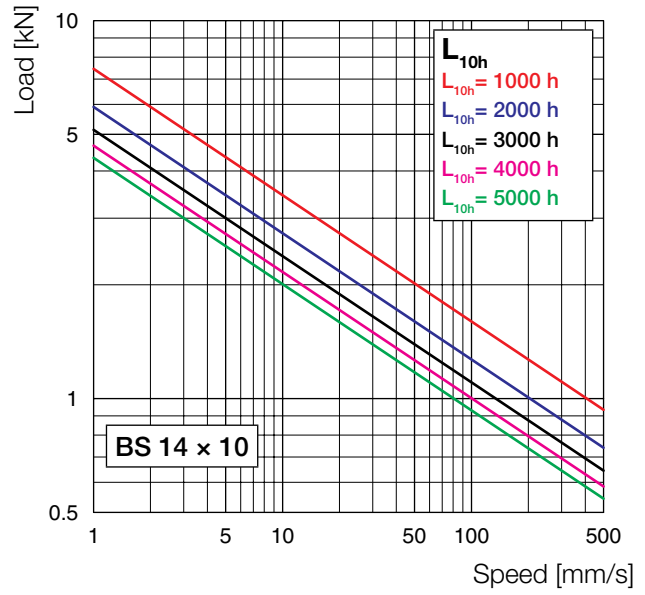
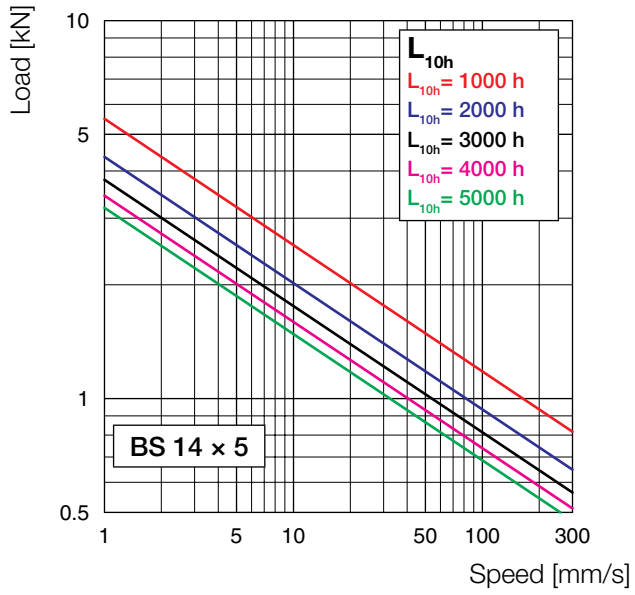

## 12. GENERAL FEATURES

### 12.3 DC MOTORS

#### Motors with interchangeable brushes (actuators ATL 10, UAL 0, BSA 10, BSA 11, UBA 0, CLB 25, CLB 27)

Permanent magnet DC motors, without fan, available with or without brake.

Long-life brushes, easy to replace.

Bipolar power supply cable 2 x 1 mm<sup>2</sup>, 1.5 m length. Motor weight: 1.3 kg.

Output power	70 W		Rated speed	3000 rpm	
Rated current	3.7 A (24 V)	8.4 A (12 V)	Rated torque	0.22 Nm	
Peak current	18 A (24 V)	30 A (12 V)	Peak torque	1.1 Nm	
Resistance	0.85 Ohm (24 V)	0.23 Ohm (12 V)	Inductance	1.34 mH (24 V)	0.36 mH (12 V)
Protection class	IP 54		Insulation class	F	

MOTOR BRAKE: Normally closed holding brake activated by DC electromagnet available on request.

Brake separately wired with bipolar cable 2 x 1 mm<sup>2</sup>, 1 m length.

Motor with brake total weight: 1.8 kg.

Power supply: 0.4 A a 24 V; 0.85 A a 12 V	Braking torque: 0.5 Nm
---	------------------------

**WARNING! The motor brake is normally closed; to open it, a constant rated voltage power supply is required. With lower voltage, the brake does not open.**

#### Motors with non-interchangeable brushes (linear actuators LMR, ATL, CLA, LMP, LMI Series)

Permanent magnet DC motors, without fan.

The brake is not available; the brushes are not interchangeable.

Standard motors winding has insulation class B.

These motors have open enclosures: the actuator is fitted with proper motor outer protections which allow to reach motor Protection Class IP 65.

The performance diagrams concerning actuators with DC motor stated in this catalogue, show the input power variation depending on the load variation.

This allows to select power supply / drivers properly.

#### Motor wires connection – Actuator push rod travelling direction

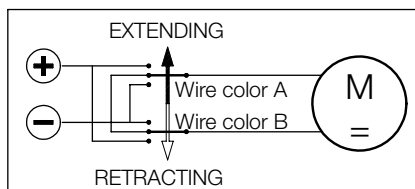

Actuator with DC motor, RIGHT-HAND mounting	LMR 01	LMR 03	ATL 02	ATL 05	ATL 08	ATL 12	CLA 20	CLA 25
Wire color A	red	red	brown	brown	brown	red	brown	brown
Wire color B	black	black	blue	blue	blue	blue	blue	blue

Actuator with DC motor, LEFT-HAND mounting	LMR 01	LMR 03	ATL 02	ATL 05	ATL 08	ATL 12	CLA 20	CLA 25
Wire color A	red	red	blue	blue	blue	blue	blue	blue
Wire color B	black	brown	brown	brown	brown	red	brown	brown

12.4 AC MOTOR							
Actuator	Motor	Power kW	N° of poles	Input voltage Vca	Frequency Hz	Rated current A	Capacitor uF
ATL 02	AC 3-phase	0.06	2	230/400	50	0,7-0,4	-
	AC 1-phase	0.06		230		0.68	5
ATL 10	AC 3-phase	0.12	2	230/400	50	0,81-0,46	-
		0.09	4			0,8-0,45	-
	AC 1-phase	0.12	2	230		2.6	12.5
		0.09	4			1.6	12.5
ATL 12	AC 3-phase	0.25	2	230/400	50	1,3-0,75	-
		0.18	4			1,1-0,66	-
	AC 1-phase	0.25	2	230		2.1	20
		0.18	4			1.9	16
CLA 20	AC 3-phase	0.06	2	230/400	50	0,7-0,4	-
	AC 1-phase	0.06		230		0.68	5
CLA 25 CLA 25S CLA 25M	AC 3-phase	0.12	2	230/400	50	0,81-0,46	-
		0.09	4			0,8-0,45	-
	AC 1-phase	0.12	2	230		2.6	12.5
		0.09	4			1.6	12.5
CLA 28 CLA 28 T	AC 3-phase	0.06	2	230/400	50	0,7-0,4	-
	AC 1-phase	0.06		230		0.68	5
BSA 10 BSA 11	AC 3-phase	0.12	2	230/400	50	0,81-0,46	-
		0.09	4			0,8-0,45	-
	AC 1-phase	0.12	2	230		2.6	12.5
		0.09	4			1.6	12.5
BSA 12	AC 3-phase	0.25	2	230/400	50	1,3-0,75	-
		0.18	4			1,17-0,66	-
	AC 1-phase	0.25	2	230		2.1	20
		0.18	4			1.9	16
CLB 25 CLB 27	AC 3-phase	0.12	2	230/400	50	0,81-0,46	-
		0.09	4			0,8-0,45	-
	AC 1-phase	0.12	2	230		2.6	12.5
		0.09	4			1.6	12.5



12.4 AC MOTOR							
Insulation class (1)	Motor protection class (1)	Fan	Brake	Brake coil power supply (2) (3)	Brake rated current A	Braking torque Nm	Brake protection class
F	IP 55	Not available	Not available	-	-	-	-
F	IP 55	Standard	On request	DC powered by rectifier	0.05	1.7	IP 44
F	IP 55	Standard	On request	DC powered by rectifier	0.09	4	IP 44
F	IP 55	Not available	Not available	-	-	-	-
F	IP 55	Standard	On request	DC powered by rectifier	0.05	1.7	IP 44
F	IP 55	Standard	Not available	-	-	-	-
F	IP 55	Standard	On request	DC powered by rectifier	0.05	1.7	IP 44
F	IP 55	Standard	On request	DC powered by rectifier	0.09	4	IP 44
F	IP 55	Standard	On request	DC powered by rectifier	0.05	1.7	IP 44

(1) Higher insulation and protection classes available on request.

(2) Normally closed activated by DC electromagnet.  
The electromagnet is powered by a 1-phase rectifier fitted in the terminal box.

(3) Motors with separately powered brake available on request.  
This solution shall be used for applications with frequency inverter.

## GENERAL NOTE

In case the linear actuator is used in an application where the stroke end switches must be connected to PLC or PC, we suggest to make the connection with a galvanic separation circuit.

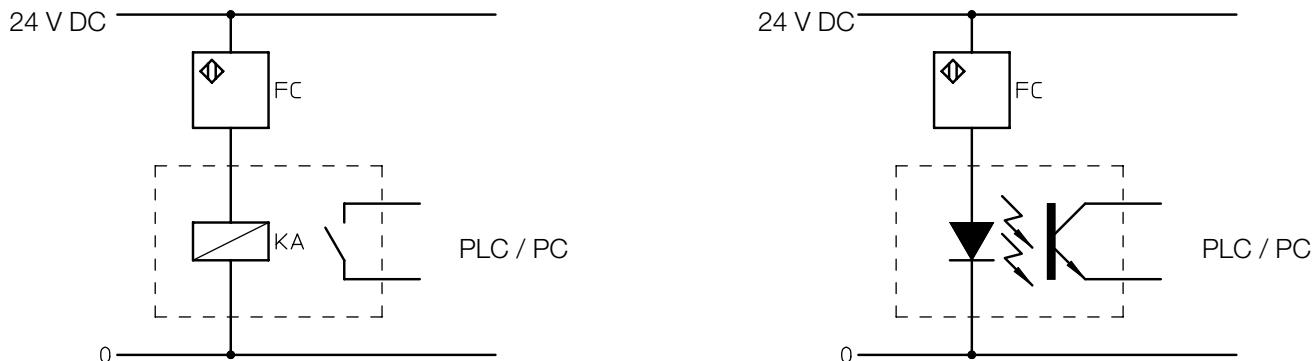

### 13.1 Magnetic stroke end switches (reed) FCM (linear actuators ATL, BSA, UAL, UBA Series, LMI 02 and LMP 03)

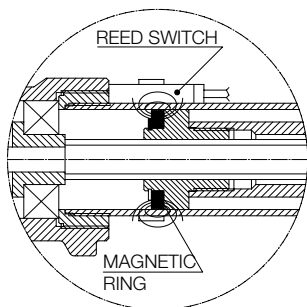

The magnetic field of the ring fixed on the nut activates the reed contact of the switch locked on the protective tube with a clamp.

The position of the switches along the tube is easily adjustable.

The switches used to determine any intermediate position (between  $L_c$  and  $L_a$ ) will switch over in two different positions, depending on the push rod motion direction (extending or retracting).

**WARNING!** The magnetic reed-switches can work only if connected to a wiring control circuit in order to activate the electric relay. Do not connect them in series between the power supply and the electric motor!

#### REED CONTACT RATED VALUE

	DC	AC
Rated voltage	(3 ... 130) V	(3 ... 130) V
Max. commutable power	20 W	20 VA
Max. commutable current	300 mA (resistive load)	
Max. inductive load	3 W	

**Standard: NC switch** (normally closed contact) equipped with signalling LEDs and protective varistor against voltage peaks.

**Standard cable length 2 m; wires 2 × 0.75 mm<sup>2</sup>**

Different configurations available on request: NO (normally open); CS (exchanging contact).

For more information please contact our Technical Dpt.

### 13.2 Electric stroke end switches FCE (actuators ATL 10, ATL 12, BSA 10, BSA 12)

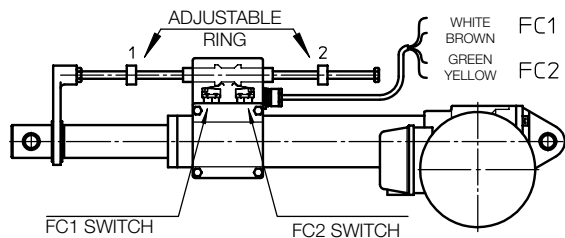

Two electric switches, installed inside a sealed plastic box, are activated by two adjustable rings through a shaft collar.

**Standard switches are wired on the NC contact, cable length 1.5 m; wires 4 × 0.75 mm<sup>2</sup>**

On request, they can be wired on the NO contact or on the switch-over contact CS (for available configurations please contact our Technical Dpt).

**Min retracted length  $L_c$**  is adjusted by ring 1. FC1 switch is connected with the WHITE and the BROWN cables.

**Max extended length  $L_a$**  is adjusted by ring 2. FC2 switch is connected with the YELLOW and the GREEN cables.

The position of the brass rings along the stainless steel supporting rod is easily adjustable.

#### CONTACT RATED VALUE

Voltage	Max current	
	Resistive load	Inductive load
250 Vac	5 A	3 A
30 Vdc	5 A	0.1 A
125 Vdc	1.4 A	-

**WARNING!** The electric reed switches can work only if connected to a wiring control circuit in order to activate the electric relay. Do not connect them in series between the power supply and the electric motor!

## 13.5 Encoder GI (linear actuators LMR 01, LMR02, LMR 03 and LMP03)

Hall effect, bi-directional, incremental encoder

Output configuration: PUSH-PULL

Code GI 21: 2 output channels, 1 pulse per revolution

Code GI 24: 2 output channels, 4 pulses per revolution

Cable length: as motor cable

Protected against polarity inversion

Protected against any incorrect output connection

NOTE: For conductive cables colour, please refer to the wiring diagram in the “Installation Instructions” supplied with the product.

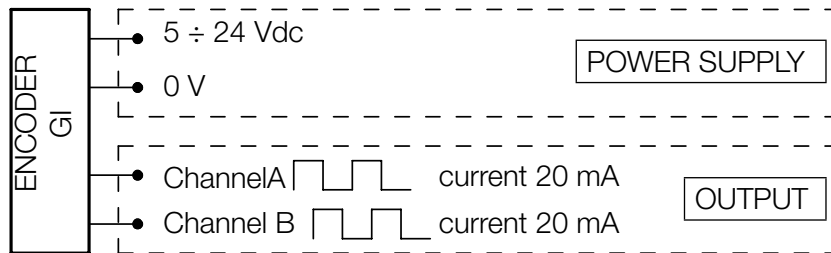

## 13.6 Encoder EH38 (linear actuators ATL 10, UAL 0, BSA 10, UBA 0)

Bi-directional, incremental, optical encoder

Output configuration: PUSH-PULL

Code EH38: 2 output channels, 100 pulses per revolution, with zero set pulse

Cable length: 1.3 m

Protected against short circuit

Protected against polarity inversion

Protected against any incorrect output connection

Input voltage: 8÷24 Vcc

No load power consumption: 100 mA

Max. commutable current: 50 mA per channel

NOTE: Safety clutch FS cannot be used with rotative encoder (the position reference would be lost due to its slipping).

