

OVERALL DIMENSIONS

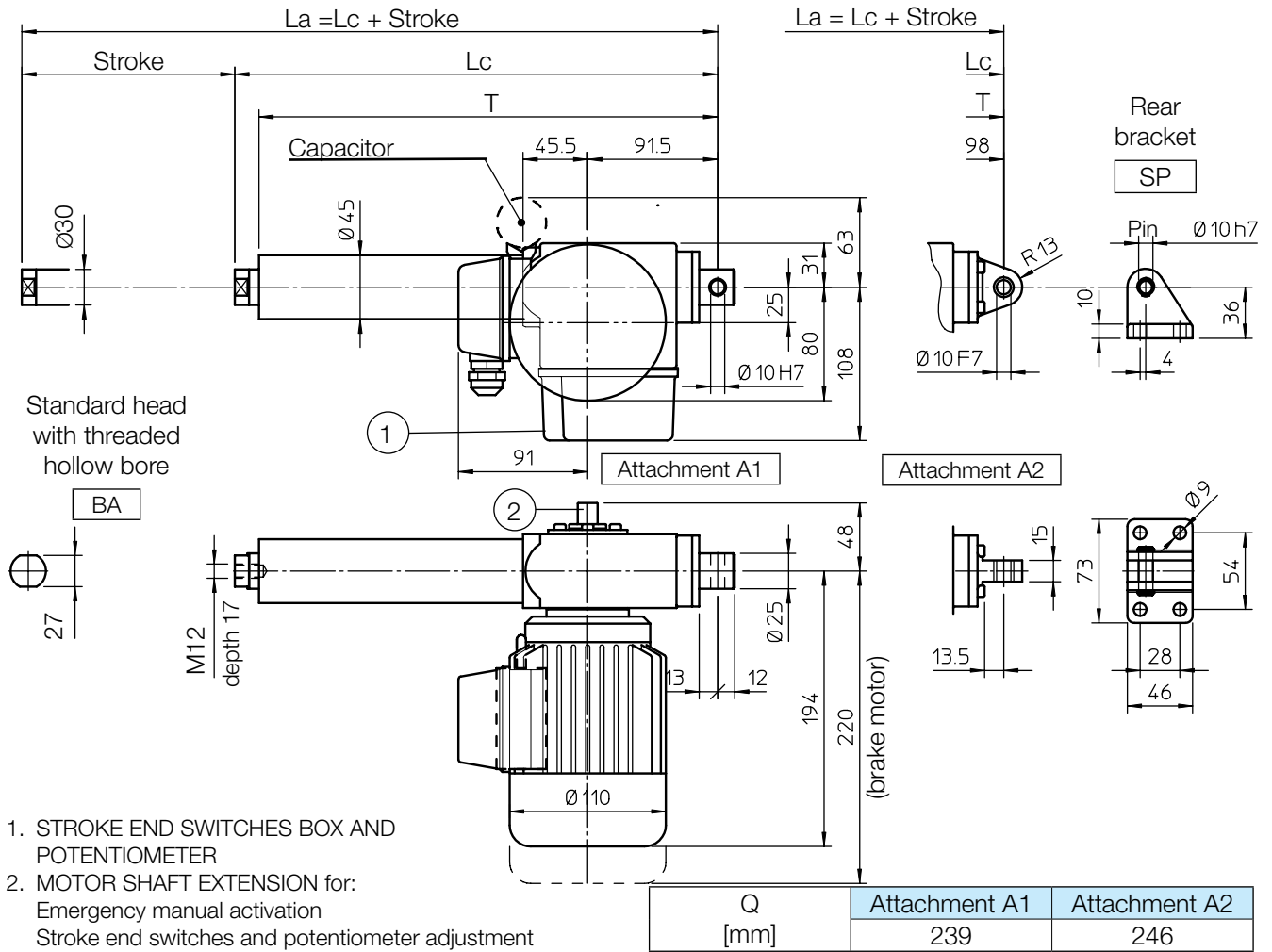

1. STROKE END SWITCHES BOX AND POTENTIOMETER
2. MOTOR SHAFT EXTENSION for:
Emergency manual activation
Stroke end switches and potentiometer adjustment

STROKE CODE	Actuator - Attachment A1				Actuator - Attachment A2				MASS [Kg]	
	STROKE [mm]	LENGTH		T [mm]	STROKE [mm]	LENGTH		T [mm]	standard motor	brake motor
		Lc [mm]	La [mm]			Lc [mm]	La [mm]			
C100	100	336	436	300	100	343	443	307	5.3	5.8
C150	150	386	536	350	150	393	543	357	5.5	6.0
C200	200	436	636	400	200	443	643	407	5.7	6.2
C300	300	536	836	500	300	543	843	507	6.1	6.6
C400	400	636	1036	600	400	643	1043	607	6.5	7.0
C500	500	736	1236	700	500	743	1243	707	6.9	7.4

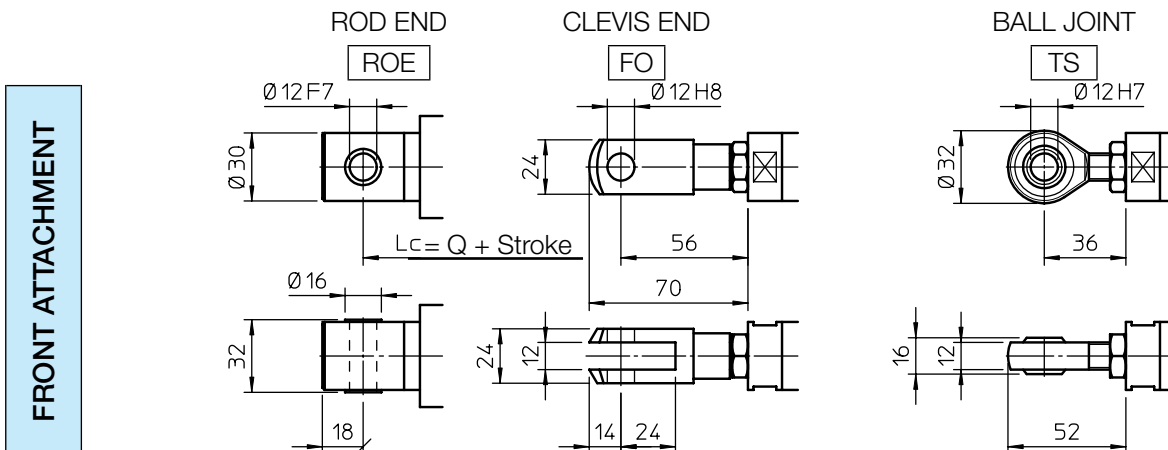

PERFORMANCES AND FEATURES

- Push load up to 7 000 N
- Pull load up to 4 000 N
- Linear speed up to 58 mm/s
- Standard stroke lengths:
100, 150, 200, 300, 400, 500 mm
- Ball screw BS 16 x 5 (technical details on page 66)
- Aluminium alloy housing
- Anodized aluminium outer tube
- Chrome-plated steel push rod
- Rear attachment:
 - A1: zinc-plated steel rod end with bronze bush
 - A2: aluminium alloy with bronze bush
- Standard head BA or rod end ROE
in stainless steel AISI 303 with bronze bush
- AC 3-phase or 1-phase motor
(motor features details on page 70)
- Duty cycle with max load:
100% over 10 min at (-10 ... +40) °C
- Standard protection IP 55 (IP 54 with brake)
- Standard motor mounting position as per sketch
(right-hand, code RH)
- Long-life lubrication, maintenance free

ACCESSORIES

- Different front attachments
- Stainless steel push rod (code SS)
- Rear bracket (code SP) with rear attachment A2
- Mechanical overload protection:
safety clutch (code FS)
- Brakemotor
- Adjustable electric stroke end switches (code FC2)
- Adjustable electric stroke end switches,
switching off the motor (code FC2X)
(not available with AC 3-phase motor)
- Extra switch for intermediate position (code FC)
- Rotative potentiometer 5kOhm for positioning control
(code POR5K)

NOTE: Extra limit switch and rotative potentiometer cannot be selected together

OPTIONS

- Motor mounting position on opposite side
(left-hand, code LH)
- Fixing attachment turned at 90° (code RPT 90)

PERFORMANCES with AC 3-phase 50 Hz 230/400 V or 1-phase 50 Hz 230 V motor

Ball screw BS 16 x 5				
RATIO	0.09 kW - 4 pole motor		0.12 kW - 2 pole motor	
	LOAD [N]	SPEED [mm/s]	LOAD [N]	SPEED [mm/s]
RH1	2160	29	1480	58
RV1	3260	19	2300	37
RN1	5990	9.5	4170	19
RL1	7000	4.5	7000	9.5

Self-locking conditions

Self-locking condition is achievable with brake motor only.

Information about statically self-locking conditions with pull or push load on page 68.

ORDERING CODE EXAMPLE

CLB 27	RL1	C200	CA 400 V	FC2	POR 5K				
Actuator	Selected ratio	Required stroke	Motor	Stroke end switches	Accessories			Options	

12.1 Ball screws

Rolled ball screw, tolerance class IT7.

Screws material: steel 42 CrMo 4 (UNI EN 10083-1) induction hardening treatment for surface hardness 58÷61 HRc

Nuts material: steel 18 NiCrMo 5 (UNI EN 10084) hardened and ground, surface hardness 58÷61 HRc, with balls surface microfinishing.

Standard axial backlash between screw and nut lower than 0.1 mm.

Executions with zero backlash or preloaded available on request.

Rolled ball screws and ball nuts are completely made in Italy, in-house manufactured by Servomech SpA S.U, Bologna.

Actuator	Ball screw	Ball diameter [mm]	Nr of ball circuits	Dynamic load C_a [N]	Static load C_{0a} [N]
BSA 08	BS 14 × 5	3.175	2	4 900	6 200
BSA 10	BS 14 × 5	3.175	2	4 900	6 200
BSA 11	BS 14 × 10	3.175	2	5 300	6 900
CLB 25	BS 14 × 5	3.175	2	4 900	6 200
	BS 14 × 10	3.175	2	5 300	6 900
CLB 27	BS 16 × 5	3.175	3	7 800	11 400
BSA 12	BS 20 × 5	3.175	3	9 100	15 400
UBA 0	BS 14 × 5	3.175	2	4 900	6 200
	BS 14 × 10	3.175	2	5 300	6 900

Static and dynamic load according to norm ISO 3408 and DIN 69051

Ball screws LOAD - LIFETIME diagram

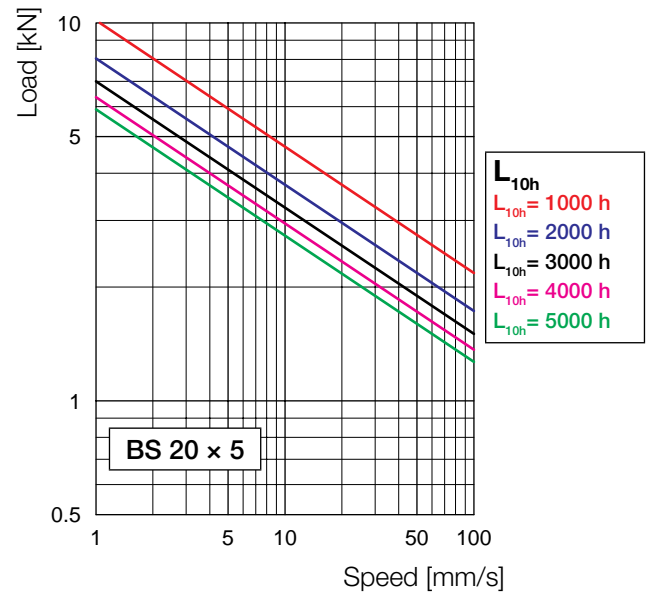
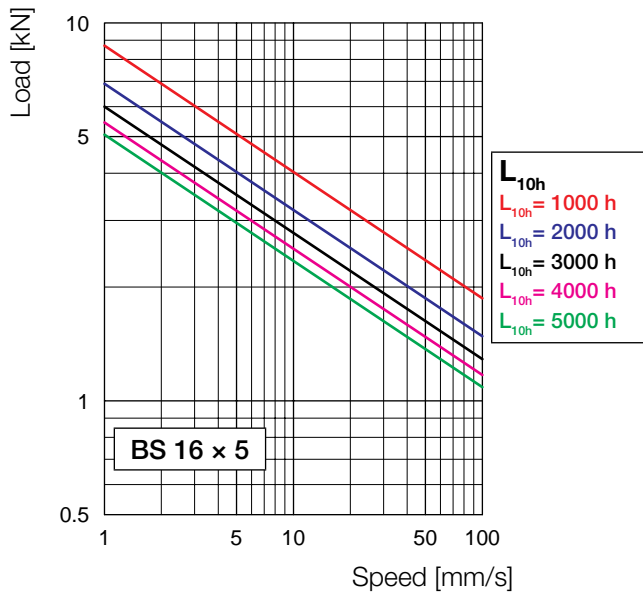
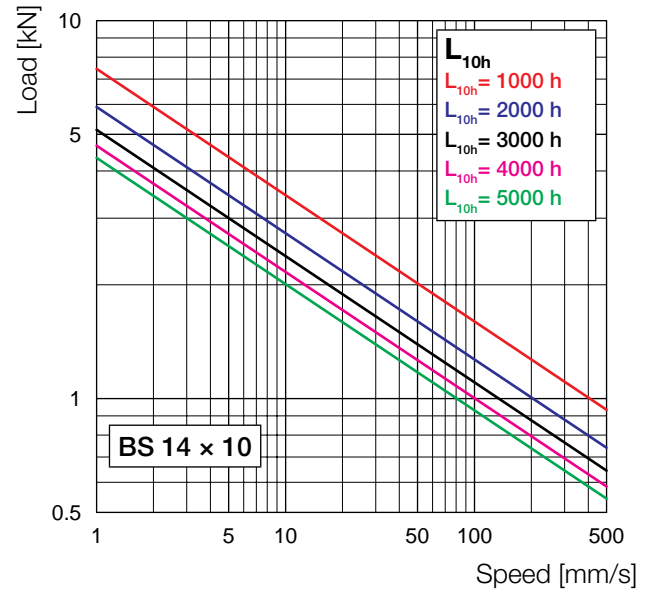
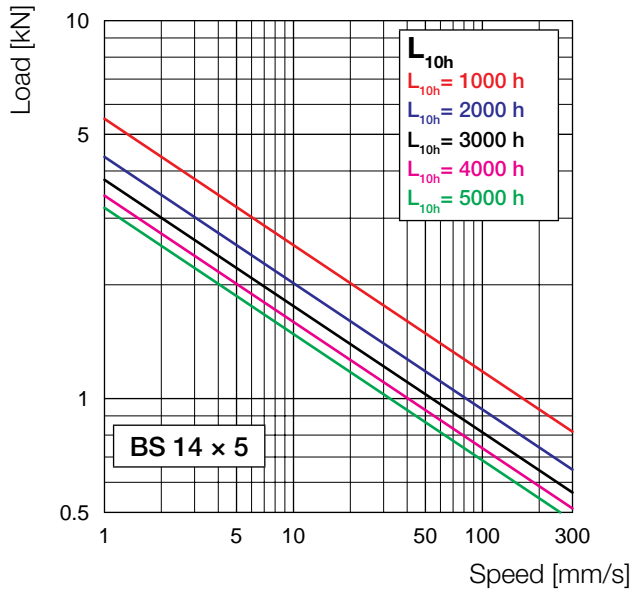

12.4 AC MOTOR							
Actuator	Motor	Power kW	N° of poles	Input voltage Vca	Frequency Hz	Rated current A	Capacitor uF
ATL 02	AC 3-phase	0.06	2	230/400	50	0,7-0,4	-
	AC 1-phase	0.06		230		0.68	5
ATL 10	AC 3-phase	0.12	2	230/400	50	0,81-0,46	-
		0.09	4			0,8-0,45	-
	AC 1-phase	0.12	2	230		2.6	12.5
		0.09	4			1.6	12.5
ATL 12	AC 3-phase	0.25	2	230/400	50	1,3-0,75	-
		0.18	4			1,1-0,66	-
	AC 1-phase	0.25	2	230		2.1	20
		0.18	4			1.9	16
CLA 20	AC 3-phase	0.06	2	230/400	50	0,7-0,4	-
	AC 1-phase	0.06		230		0.68	5
CLA 25 CLA 25S CLA 25M	AC 3-phase	0.12	2	230/400	50	0,81-0,46	-
		0.09	4			0,8-0,45	-
	AC 1-phase	0.12	2	230		2.6	12.5
		0.09	4			1.6	12.5
CLA 28 CLA 28 T	AC 3-phase	0.06	2	230/400	50	0,7-0,4	-
	AC 1-phase	0.06		230		0.68	5
BSA 10 BSA 11	AC 3-phase	0.12	2	230/400	50	0,81-0,46	-
		0.09	4			0,8-0,45	-
	AC 1-phase	0.12	2	230		2.6	12.5
		0.09	4			1.6	12.5
BSA 12	AC 3-phase	0.25	2	230/400	50	1,3-0,75	-
		0.18	4			1,17-0,66	-
	AC 1-phase	0.25	2	230		2.1	20
		0.18	4			1.9	16
CLB 25 CLB 27	AC 3-phase	0.12	2	230/400	50	0,81-0,46	-
		0.09	4			0,8-0,45	-
	AC 1-phase	0.12	2	230		2.6	12.5
		0.09	4			1.6	12.5

12.4 AC MOTOR							
Insulation class (1)	Motor protection class (1)	Fan	Brake	Brake coil power supply (2) (3)	Brake rated current A	Braking torque Nm	Brake protection class
F	IP 55	Not available	Not available	-	-	-	-
F	IP 55	Standard	On request	DC powered by rectifier	0.05	1.7	IP 44
F	IP 55	Standard	On request	DC powered by rectifier	0.09	4	IP 44
F	IP 55	Not available	Not available	-	-	-	-
F	IP 55	Standard	On request	DC powered by rectifier	0.05	1.7	IP 44
F	IP 55	Standard	Not available	-	-	-	-
F	IP 55	Standard	On request	DC powered by rectifier	0.05	1.7	IP 44
F	IP 55	Standard	On request	DC powered by rectifier	0.09	4	IP 44
F	IP 55	Standard	On request	DC powered by rectifier	0.05	1.7	IP 44

(1) Higher insulation and protection classes available on request.

(2) Normally closed activated by DC electromagnet.
The electromagnet is powered by a 1-phase rectifier fitted in the terminal box.

(3) Motors with separately powered brake available on request.
This solution shall be used for applications with frequency inverter.

13.4 Electric cam-operated stroke end switches (linear actuators CLA and CLB Series)

Code **FC2**: two electric cam-operated switches, wired on contact NC (to be connected into the external control circuit). On request, the switches can be wired on the contact NO or on the switch-over contact CS. (For available configurations please contact our Technical Dpt).

Code **FC2X**: two electric cam-operated switches, internally wired between power supply and electric motor, in order to switch off the power supply directly, without relays. Available for actuators with Dc or AC 1-phase motor.

Code **FC2 + FC** or **FC2X + FC**: Stroke end switches FC2 or FC2X with a third switch for any intermediate position. The third switch can be wired on contact NC or NO on request. (For different configurations please contact our Technical Dpt).

SWITCH RATED VALUES		
Voltage	Max current	
	Resistive load	Inductive load
250 Vac	21 A	12 A
30 Vdc	14 A	12 A
125 Vdc	0.8 A	0.6 A

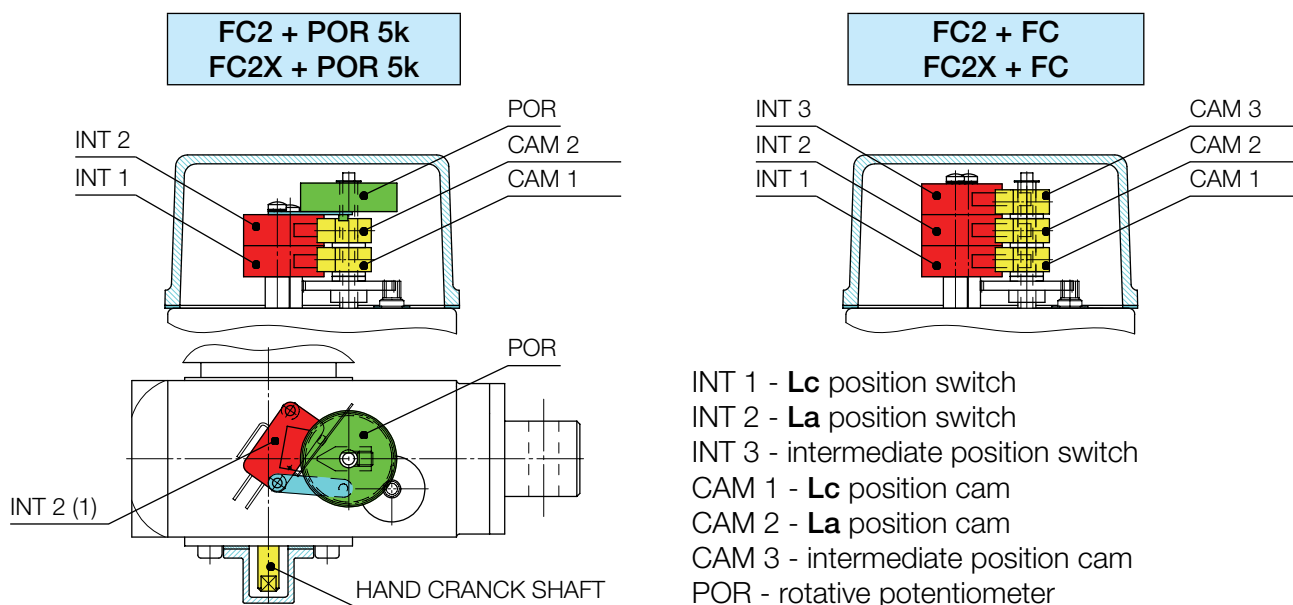

Lc = actuator retracted length, **La = Lc + Stroke** – actuator extended length

13.4 Rotative potentiometer for positioning control (linear actuators CLA and CLB Series)

Code **POR 5k**: rotative potentiometer, single turn (340°), 5 kOhm ± 20 %, linearity ± 2 %

The rotative potentiometer is an absolute transducer, whose output signal is proportional to the current position of the actuator push rod. Analogic output signal.

Standard cable: 4 x 0.25 mm² + shield, 1.5 m length (for different configurations please contact us).

POR 5k standard wiring diagram:

POR Power supply: 0 V dc

Reference signal: ZERO

Reference signal: RETURN

POR Power supply: + V cc

SHIELD

